

1. Slide AVIVA™ Dispenser container up and off the bracket that is on the wall.
2. Insert a small screw driver into the bottom opening of the faceplate just in front of the pump nozzle, (as shown in the diagram).
3. Slowly pry off face plate.
4. Pull off the push button.
5. Pry the bottom retainer from liquid bottle exposing the pump. (you might need a screw driver to assist you)
6. Unscrew the pump from the liquid container.
7. Remove the valve, from the neck of the liquid container and replace it with the new valve.
8. Re-assemble, first put on the bottom retainer, then button, and faceplate.

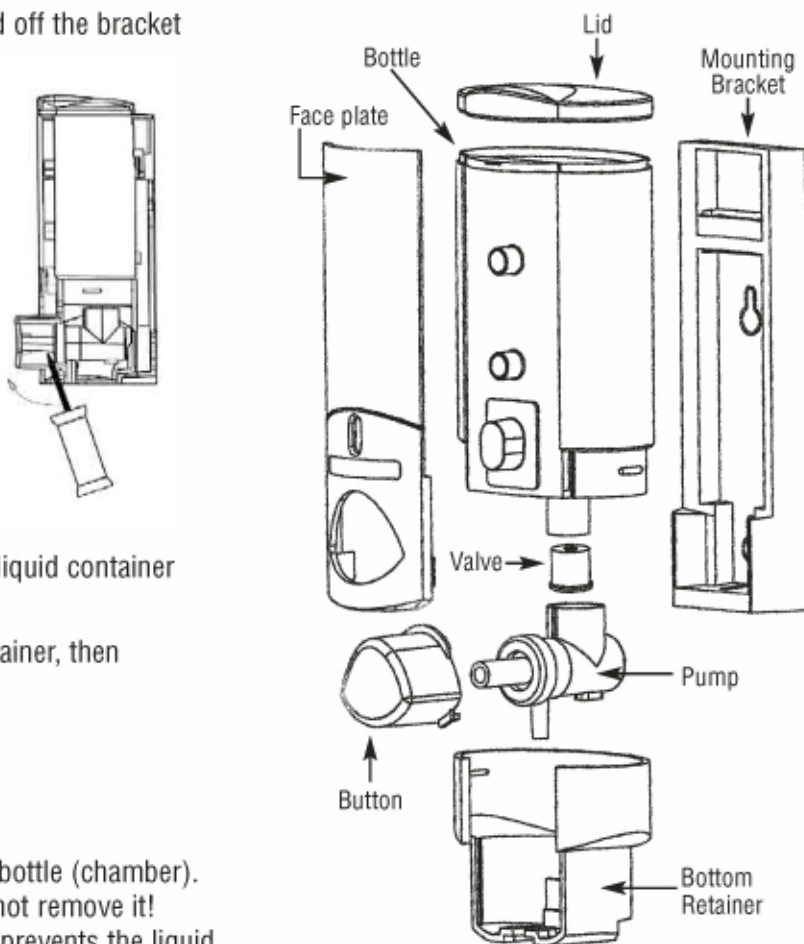

## How The Dispenser pump works

There is a valve located in the bottom of the bottle (chamber). It must be there for the system to work. Do not remove it! When the pump button is pushed, this valve prevents the liquid in the pump, from going back up into the bottle. Without this valve, liquid will not flow properly.

## Priming the Pump

NOTE: No liquid will come out of The **Dispenser** until the pump has been primed. Once it is primed, it will stay primed until the liquid runs out. If the chambers become empty, you must re-prime the pump.

